

INFINITY[®]
SERIES
THE NEW STANDARD FOR QUALITY

IDT

INFINITY™ D

Thermocouple Meter

Operator's Manual



N[®] **Newport Electronics, Inc.**

Additional products from

NEWPORT Electronics, Inc.

Counters	Rate Meters
Frequency Meters	Timers
PID Controllers	Totalizers
Clock/Timers	Strain Gauge Meters
Printers	Voltmeters
Process Meters	Multimeters
On/Off Controllers	Soldering Iron Testers
Recorders	pH pens
Relative Humidity	pH Controllers
Transmitters	pH Electrodes
Thermocouples	RTDs
Thermistors	Thermowells
Wire	Flow Sensors

For Immediate Assistance
In the U.S.A. and Canada: 1-800-NEWPORT®
In Mexico: (95) 800-NEWPORTSM
Or call your local NEWPORT Office.

NEWPORTnetSM On-Line Service

<http://www.newportUS.com>

Internet e-mail

info@newportUS.com

It is the policy of NEWPORT to comply with all worldwide safety and EMC/EMI regulations that apply. NEWPORT is constantly pursuing certification of its products to the European New Approach Directives. NEWPORT will add the CE mark to every appropriate device upon certification.

The information contained in this document is believed to be correct but NEWPORT Electronics, Inc. accepts no liability for any errors it contains, and reserves the right to alter specifications without notice.

WARNING: These products are not designed for use in, and should not be used for, patient connected applications.

PATENT NOTICE: The "Meter Case Bezel Design" is a trademark of NEWPORT Electronics, Inc., registered in the U.S. This product is covered by one or more of the following patents: U.S. No. D336,895; 5,274,577/ FRANCE BREVET No. 91 12756/ UK PATENT No. 2,248,954; 2,249,837/ SPAIN 2,039,150; 9,102,259/ ITALY 1,249,456; 1,250,938/ CANADA 2,052,600/ GERMANY DE 4134398C2. OTHER INTERNATIONAL PATENTS PENDING.



This device is marked with the international caution symbol. It is important to read the Setup Guide before installing or commissioning this device as it contains important information relating to safety and EMC.

1.1 Before You Begin

1.1.1 *Customer Service*

If you need assistance, the Newport Electronics Customer Service Department is available at 800-NEWPORT or 714-540-4914 from 7:00am until 5:00pm Pacific Standard Time.

1.1.2 *Inspecting Your Shipment*

Remove the packing slip and verify that you have received everything listed, including:

- 1 IDT indicator/controller with all applicable connectors attached
- 1 IDT Owner's Manual
- 1 IDT Quick Start Manual

**Note**

If you ordered any of the available options (except the “BL” blank Lens option), they will be shipped in a separate container to avoid any damage to your indicator/controller.

**Warning!**

Inspect the container and equipment for signs of damage as soon as you receive the shipment. Note any evidence of rough handling in transit. Immediately report any damage to the shipping agent. The carrier will not honor damage claims unless all shipping material is saved for inspection. After examining and removing the contents, save the packing material and carton in the event reshipment is necessary.

**1.1.3 What
You Will
Need**

In addition to the meter and connectors, you will need the following items to setup your unit:

115VAC three-prong power cord

1/8" flat head screwdriver

1.2 Features and Options

1.2.1 Basic Features

Your meter has several basic features, some of which are listed below. For more detailed information on specifications and factory defaults, see *Part 3: Defaults & Specifications*.

- 4 digit, 7 segment LED display with programmable decimal point

- Nonvolatile memory — no battery backup necessary

- 115Vac or 230Vac 50/60 Hz power source

1.2.2 IDT Options

The IDT unit is available with an optional NEMA-4 front panel cover. Please contact Newport Customer Service for a list of additional products and accessories.

1.3 Safety Considerations

The IDT is protected in accordance with Class II of IEC 348 and VDE 0411. Remember that the unit has no power-on switch. It will be in operation as soon as you connect it to a power source.

**Warning!**

Do not expose the unit to rain or moisture. Do not operate your unit in flammable or explosive atmospheres. As with any electronic instrument, you may encounter high voltage exposure when installing, calibrating, or removing parts. Be careful when working near conductors carrying large currents. Use twisted-pair connections to the unit. Use magnetic shielding materials, or move the unit away from the current source to reduce magnetic field problems. Do not exceed power rating on label located on the top of the controller housing. **Failure to follow all instructions and warnings may result in injury!**

1.4 Getting Started

Overview

Follow these steps to start using your unit right away:

- Mount the unit
- Connect Sensor Input
- Connect the AC power cord
- Turn on the unit

1.4.1 Mount the Unit

1. Remove the two nuts at the back of the unit, which hold the mounting sleeve. Remove the sleeve.
2. Cut a hole in your panel, as shown.

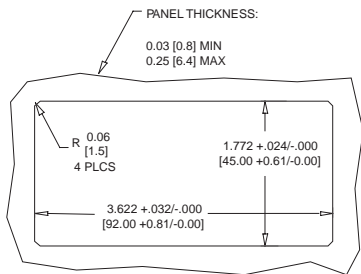
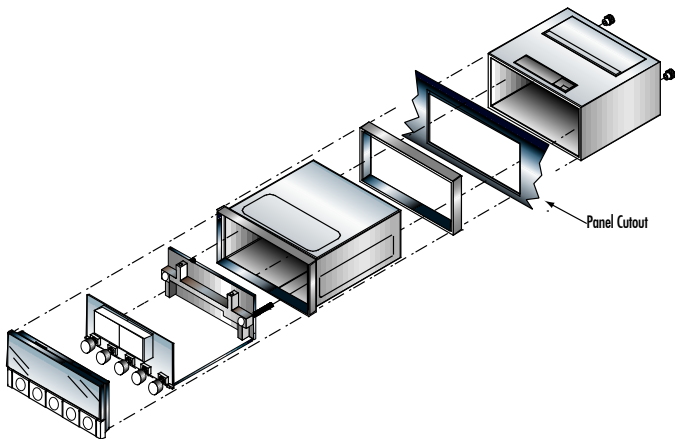

Figure 1.1 – Panel Cut-out Dimensions

3. Insert the unit into the hole. Be sure the front bezel is flush to your panel. Slide on the mounting sleeve from the rear of the panel and tighten the unit until snug, using the two nuts.



1.4.2 Connect Sensor Input

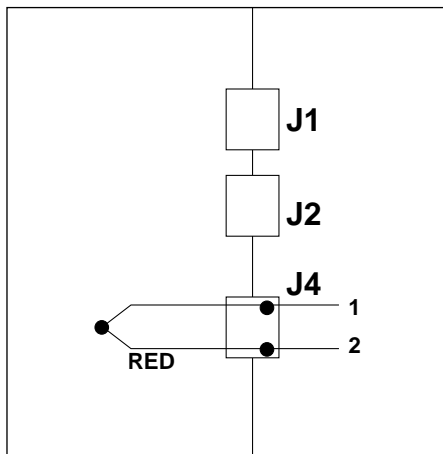

Figure 1.3 – Thermocouple Input Connection

1.4.3

Connect the AC Power Cord

1. Locate the connector pins. (*see Figure 3.1*)



Warning!

Do not connect AC power to your unit until all input and output connections have been properly established. **Failure to do so may result in injury.**

2. Insert the correct wire in each terminal and tighten the lockdown screw. See Table 1.1 for wire color definitions. Tug gently on the wires to verify that the connections are secure.

Connection	Europe	USA
AC-High	Brown	Black
AC-Low	Blue	White
AC -Ground	Green/Yellow	Green

Table 1.1 – AC Power Wire Color & Connections

1.4.4 Turn On the Unit

1. Plug the unit into a properly grounded 115V power supply. The unit will initialize, scrolling the following three messages on the front panel:

idk

codE

r 01

(**r 01** equals the revision code of the micro controller. **Keep track of the revision code for future reference.**)

2. The present value of the Thermocouple should be displayed. If a value is not displayed, follow these steps:
 - Unplug the unit
 - Verify the power and TC connections
 - Check your power source
 - Plug the unit in again

2.1 Introduction

The IDT has two different modes of operation. The first, Run Mode, is used to display process value and display or clear peak and valley values. The other mode, Configuration Mode, is used to navigate through the menu options and configure the meter.

**Note**

The S51 jumper must be removed (which is the factory setting) and the S4 jumper must be installed (which is *not* the factory setting) for all menu configuration options to be available. (See page 34 for further jumper information.)

**Overview**

This part of the manual, *Operation*, will explain both the Run Mode and the Configuration Mode and is divided into the following sections:

- Meter Buttons
- Display Descriptions
- Menu Configurations

2.2 Meter Buttons

Button	Description
RESET	Reset the peak and valley values
MENU	Enter Configuration (Menu) mode
▶/MIN	Display the valley value (flashing)
▲/MAX	Display the peak value (flashing)
C/F	Toggle display between °C and °F

Table 2.1 – Button Functions

2.3 Display Descriptions

Display Message	Description
nnnn	Peak value to follow
uuuu	Valley value to follow
OL	Open thermocouple input
rSt	Peak/Valley Reset

Table 2.2 – Display Descriptions

2.4 Menu Configurations

TYPE

2.4.1 Selecting the Input Thermocouple Type

The IDT is designed to handle up to eight different thermocouple types. To select the thermocouple type, follow these steps:

1. Press the MENU button. The meter will momentarily displays:

TYPE

2. Press the /MIN button. You may scroll through the following choices:

Displayed as:

J	J
K	K
T	T
E	E
N	N
01N J	01n J
R	r
S	S

2. Press the /MIN button to scroll through available choices
3. Press the MENU button to store and activate your selection.

DECP

2.4.2 Selecting the Decimal Point

The IDT can display temperatures in 1° or 0.1° resolution. **When using type R or S the meter will only be indicating with 1° resolution. The DECP menu item will not be available for these two types of thermocouples.**

1. Press MENU until display displays:

dEcP

2. After a moment the display will indicate the currently selected decimal point (resolution) configuration.
3. **AUTO** will be displaced if the meter is configured to display any temperature between -100° and 1000° with 0.1 resolution (meter will switch to 1° resolution above and below these temperatures automatically.)
4. **1dEG** will be displayed when the meter is configured for 1° resolution.
5. Pressing the **▶/MIN** button allows you to toggle between these choices:

AUTO	($0.1^{\circ}/1^{\circ}$)
1dEG	(1°) resolution
6. Press the MENU button to save and activate your selection.

2.4.3 Meter Cold-Junction Offset Calibration procedure

This menu item will allow you to adjust the cold junction offset calibration.

1. Press MENU until meter flashes:

CJ 2 (cold junction zero)

2. **Connect the proper thermocouple to the input at J4 and using a thermocouple calibrator apply 0.0°C.**
 3. Press ▲/MAX to display the cold-junction offset. (If the meter reading at this point is more than 5.0 recheck your Thermocouple connections and make sure 0.0°C is applied.)
 4. The Cold-junction calibration on the IDT is semi-automatic. Press ▲/MENU to activate the internal compensation. The display will begin to flash and automatically adjust the offset reading on the display to 0.0 (± 0.1)
-

This automatic cold junction calibration should be all that is necessary to calibrate the CJ offset, however if you want to additionally adjust the offset manually, the ▲/MAX and ►/MIN buttons at this point can be used to manually increase (▲/MAX) or decrease (►/MIN) the display 0.1° each time ▲/MAX or ►/MIN is pressed. After each press allow several seconds to let the display stabilize. Press MENU to save and activate the calibration. (Meter will briefly display *5tor.*)

The following menu items will only be available with S4 installed.

CNFG **CF = 0** DEFAULT

CNFG **CF = 1,2** Functions not available

LINE 50H 60H **60H** DEFAULT

CAL = For use only by qualified personal with accurate calibration equipment

LINE**2.4.4 Line Frequency Selection**

This item will only be available if the S4 jumper, which enables the calibration configuration, is installed!

This menu item will allow you to select the local line frequency used by the meter.

1. Press MENU until display displays:

LINE

2. After a moment the display will indicate the currently selected line frequency.
3. Pressing the **▶/MIN** button allows you to toggle between these choices:

50H (50 Hz)

60H(60 Hz)

4. Press the MENU button to save and activate your selection.

CAL

2.4.5 Calibration Menu

Caution: It is not necessary to calibrate a brand new meter, it arrives completely calibrated. Accessing the calibration menu will affect the meter's calibration and should only be performed by qualified personnel with accurate test equipment.

2.4.5.1 Meter SPAN calibration procedure

This item will only be available if the S4 jumper, which enables the calibration configuration, is installed!

The Span calibration does *not* require any special compensated thermocouple wires at the input terminals. Standard copper wire hooked up to a mV calibration source is required.

This menu item will allow you to adjust the SPAN calibration used by the meter.

1. Press MENU until meter flashes:

CAL

2. Press **▶**/MIN button. Meter will now display:

SPC (Span Calibration)

3. Press **▲**/MAX button. Meter will display:

0 In

4. Apply 0 mV to input terminals 1 and 2 of J4. Let meter stabilize for 10 seconds then press MIN to accept. Meter will display:

75 In

5. Apply 75 mV to input terminals at J4. Let meter stabilize for 10 seconds then press MIN to accept. Meter will display:

0.00 mV (40 mV zero reading)

6. Apply 0 mV to input terminals at J4. Let meter stabilize for 10 seconds then press MIN to accept. Meter will display:

40.00 mV

7. Apply 40 mV to input terminals at J4. Let meter stabilize for 10 seconds then press MIN to accept.
8. Meter will briefly display $r5t$ indicating the span calibration is saved in non-volatile memory.

3.1 Back of the Meter

Figures 3.1 and 3.2 show the connectors on the back of the meter for ac and dc models respectively. Table 3.1 gives a brief description of each connector at the back of the meter.

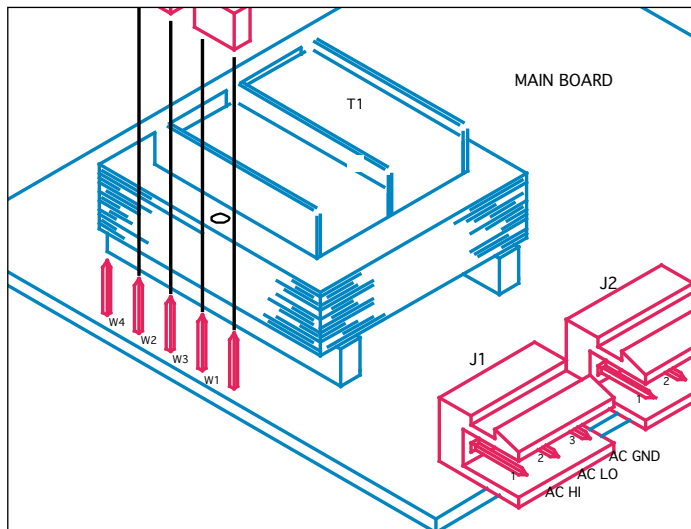

Figure 3.1 — Connectors (ac-powered)

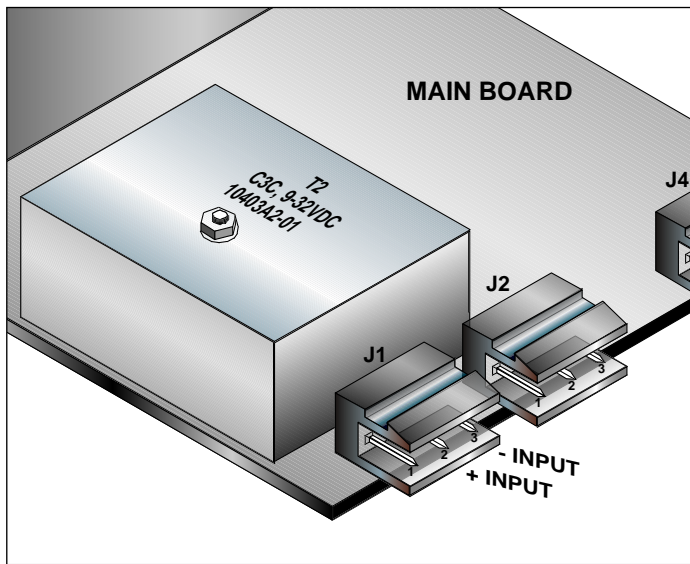

Figure 3.2 – Connectors (dc-powered)

Connector	Description
J1-1	AC high connection (NC on DC-powered units)
J1-2	AC low connection (+ input on DC-powered units)
J1-3	AC ground (DC-power return on DC-powered units)
J2-1	Display hold input (active low) — connect to J2-2 to hold meter reading. Peak and valley readings are continuously updated during display hold even though display is on hold.
J2-2	Ground
J2-3	Display blank input (active low) — connect to J2-2 to blank meter display.
J4-1	+ TC input
J4-2	- TC input (red wire)

Table 3.1 – Connector Descriptions

3.2 Main Board AC Power Jumpers

o check voltage jumpers, or to change from 115 V to 230 Vac:

- . Disconnect the AC power from the meter.
- . Remove the front lens, if present.
- . Pull the meter forward, out of its case.

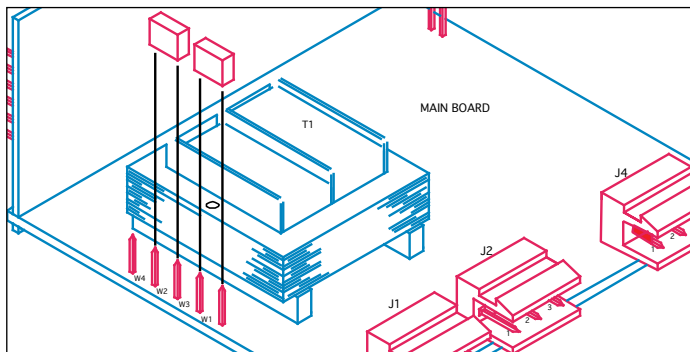

Figure 3.3 – 115Vac Jumpers (Default)

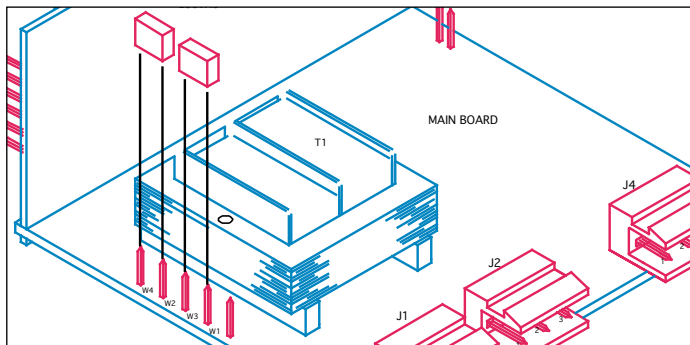

Figure 3.4 – 230Vac Jumpers

3.3 S51,-S4 Jumpers

The S51 Jumpers is at the front of the meter near the digital display. The S4 Jumpers is on the side of the main board (see figure 3.5). (Defaults are in bold *and* italic.)

- Disconnect the main power from the meter.
- Remove the front lens, if present.
- Pull the meter forward, out of its case.

Jumper	Description
S51	installed: front panel buttons locked out <i>removed:</i> all buttons operable. Jumper placed in storage position on one PIN only.
S4	installed: calibration enabled <i>removed:</i> calibration disabled. Jumper placed in storage position on one PIN only.

Table 3.2 — S51–S4 Jumpers

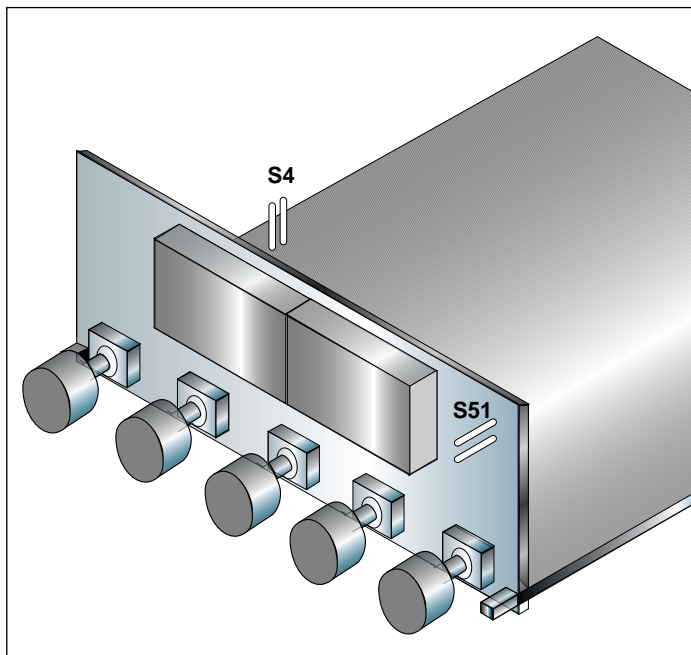

Figure 3.5 – S51,–S4 Jumpers

3.4 Specifications

3.4.1 General Specifications

	Microprocessor based
Input type:	Type J, DINJ, K, T, E, N, R, S
Max Error:	± 1 deg C (± 1.8 °F)
Accuracy at 25°C:	$\pm .5$ deg C ($\pm .8$ °C for DINJ)
Cold-junction compensation tempco	0.07°C/°C

3.4.2 Display

type:	7 segments red or green 4 digit
height:	0.56in (14.2mm)

3.4.3 Thermocouple Types

Type	Range	
	Deg C	DegF
J	-210	-346
	760	1400
DIN J	-200	-328
	900	1652
K	-270	-454
	1372	2500
T	-270	-454
	400	752
E	-270	-454
	1000	1832
R/S	-50	-58
	1768	3214
N	-270	-454
	1300	2372

3.4.4 Resolution

0.1° or 1° resolution

3.4.5 Power

115 or 230 Vac

±15% (2 Watt max.)

frequency: 50 or 60Hz

Isolation: 354V peak per IEC spacing
NMR 60dB

CMR 120 dB

DC voltage: 10–32Vdc isolated to 300Vp

3.4.6 Environmental

Operating temp: 0–60°C

Storage temp: -40 to +85°C

Relative humidity: 95% at 40°C (non condensing)

3.4.7 Case

Newport DIN 4896-100

Panel cutout: 1.77 X 3.62 in (45 X 92mm)

Depth behind bezel: 3.94 in (100mm)

material: 94V-0 UL-rated polycarbonate

3.4.8 Meter Dimensions

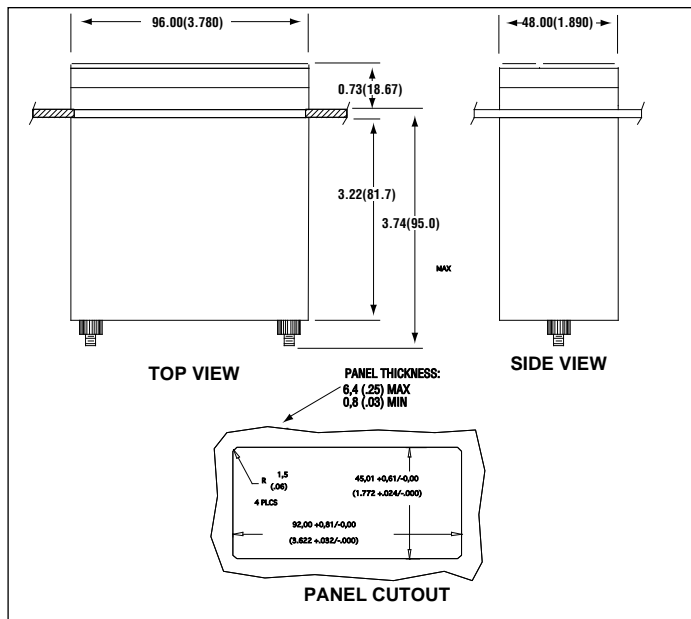

Figure 3.6 – Meter Dimensions

- alibration
 - and the S4 jumper
 - changing
 - installing/removing calibration jumper
- onfiguration jumpers
 - changing
- onfiguration mode
 - escape from
 - RESET button
 - /MAX button
 - /TARE button
- onnecting sensor input
- onnector label
 - power
 - 2-wire voltage input connection
 - 3-wire voltage input connection
 - connectors
 - current input connections
- ecimal point
 - disregarding in meter calibration
 - factory default
 - selecting
- assembly
- ont-panel buttons
 - MENU
 - RESET
 - T-RST
 - /MAX
 - /TARE
- put range
 - and internal scaling
 - calibrating
 - factory default
 - selecting
- stalling the meter

ternal scaling
ve scaling
ain board power jumpers
ENU button
eter modes
 configuration mode
 run mode
icro controller revision code
 accessing
ounting the meter
ESET button
esetting peak and valley registers
un mode
 MENU button
 RESET button
 /MAX button
 /TARE button
1 & S4 jumpers
 changing
aling
 error message
 internal
 live
aling without known loads
nsor excitation
 factory default
nsor input
 connecting
RST button
oltage calibrator
 and live scaling
MAX button
TARE button

For technical or application assistance please call:

Newport Electronics, Inc.

2229 South Yale Street • Santa Ana, CA • 92704-4426 • U.S.A.
TEL: (714) 540-4914 • FAX: (714) 546-3022
Toll Free: 1-800-639-7678 • e-mail: info@newportUS.com

Newport Technologies, Inc.

976 Bergar • Laval (Quebec) • H7L 5A1 • Canada
TEL: (514) 335-3183 • FAX: (514) 856-6886
Toll Free: 1-800-639-7678 • e-mail: info@newport.qc.ca

Newport Electronics, Ltd.

One Omega Drive • River Bend Technology Centre
Northbank, Irlam, • Manchester, M44 5EX, England
Tel: 44 (161) 777-6611 • FAX: 44 (161) 777-6622
Toll Free: 0800-488-488 • e-mail: info@newportinc.co.uk

Newport Electronics B.V.

Postbus 8034 • 1180 LA Amstelveen • The Netherlands
TEL: (31) 20 6418405 • FAX: (31) 20 6434643
Toll Free: 0800 0993344 • e-mail: nl@newportinc.com

Newport Electronics spol s.r.o.

ul. Rude armady 1868, 733 01 Karvina-Hranice • Czech Republic
TEL: 420 (69) 6311899 • FAX: 420 (69) 6311114
Toll Free: 0800-1-666432 • e-mail: info@newport.cz

Newport Electronics GmbH

Daimlerstrasse 26 • D-75392 Deckenpfronn • Germany
TEL: 49 (07056) 3017 • FAX: 49 (07056) 8540
Toll Free: 0130 11 21 66 • e-mail: info@newport.de

Newport Electronique S.A.R.L.

9, rue Denis Papin • 78190 Trappes • France
TEL: (33) 130-621-400 • FAX: (33) 130-699-120
Toll Free: 0800-4-63978 • e-mail: france@newportinc.com

Mexico and Latin America

TEL: 95-800-639-7678 • FAX: 95-203-359-7807
En Español: (203) 359-7803 • e-mail: espanol@newportinc.com

NEWPORTnetSM On-Line Service

<http://www.newportUS.com>

Internet e-mail

info@newportUS.com



Newport Electronics, Inc.

M2342/N/0896 Rev. B

Warranty/Disclaimer

NEWPORT Electronics, Inc. warrants this unit to be free of defects in materials and workmanship for a period of one (1) year from the date of purchase. In addition to NEWPORT's standard warranty period, NEWPORT Electronics will extend the warranty period for one (1) additional year if the warranty card enclosed with each instrument is returned to NEWPORT.

If the unit should malfunction, it must be returned to the factory for evaluation. NEWPORT's Customer Service Department will issue an Authorized Return (AR) number immediately upon phone or written request. Upon examination by NEWPORT, if the unit is found to be defective it will be repaired or replaced at no charge. NEWPORT's WARRANTY does not apply to defects resulting from any action of the purchaser, including but not limited to mishandling, improper interfacing, operation outside of design limits, improper repair, or unauthorized modification. This WARRANTY is VOID if the unit shows evidence of having been tampered with or shows evidence of being damaged as a result of excessive corrosion; or current, heat, moisture or vibration; improper specification; misapplication; misuse or other operating conditions outside of NEWPORT's control. Components which wear are not warranted, including but not limited to contact points, fuses, and triacs.

NEWPORT is pleased to offer suggestions on the use of its various products. However, NEWPORT neither assumes responsibility for any omissions or errors nor assumes liability for any damages that result from the use of its products in accordance with information provided by NEWPORT, either verbal or written. NEWPORT warrants only that the parts manufactured by it will be as specified and free of defects. NEWPORT MAKES NO OTHER WARRANTIES OR REPRESENTATIONS OF ANY KIND WHATSOEVER, EXPRESSED OR IMPLIED, EXCEPT THAT OF TITLE, AND ALL IMPLIED WARRANTIES INCLUDING ANY WARRANTY OF MERCHANTABILITY AND FITNESS FOR A PARTICULAR PURPOSE ARE HEREBY DISCLAIMED. LIMITATION OF LIABILITY: The remedies of purchaser set forth herein are exclusive and the total liability of NEWPORT with respect to this order, whether based on contract, warranty, negligence, indemnification, strict liability or otherwise, shall not exceed the purchase price of the component upon which liability is based. In no event shall NEWPORT be liable for consequential, incidental or special damages.

CONDITIONS: Equipment sold by NEWPORT is not intended to be used, nor shall it be used: (1) as a "Basic Component" under 10 CFR 21 (NRC), used in or with any nuclear installation or activity; or (2) in medical applications or used on humans. Should any Product(s) be used in or with any nuclear installation or activity, medical application, or used on humans, or misused in any way, NEWPORT assumes no responsibility as set forth in our basic WARRANTY / DISCLAIMER language, and additionally purchaser will indemnify NEWPORT and hold NEWPORT harmless from any liability or damage whatsoever arising out of the use of the Product(s) in such a manner.

Return Requests/Inquiries

Direct all warranty and repair requests/inquiries to the NEWPORT Customer Service Department. BEFORE RETURNING ANY PRODUCT(S) TO NEWPORT, PURCHASER MUST OBTAIN AN AUTHORIZED RETURN (AR) NUMBER FROM NEWPORT'S CUSTOMER SERVICE DEPARTMENT (IN ORDER TO AVOID PROCESSING DELAYS). The assigned AR number should then be marked on the outside of the return package and on any correspondence.

The purchaser is responsible for shipping charges, freight, insurance and proper packaging to prevent breakage in transit.

FOR **WARRANTY** RETURNS, please have the following information available BEFORE contacting NEWPORT:

1. P.O. number under which the product was PURCHASED,
2. Model and serial number of the product under warranty, and
3. Repair instructions and/or specific problems relative to the product.

FOR **NON-WARRANTY** REPAIRS, consult NEWPORT for current repair charges. Have the following information available BEFORE contacting NEWPORT:

1. P.O. number to cover the COST of the repair,
2. Model and serial number of product, and
3. Repair instructions and/or specific problems relative to the product.

NEWPORT's policy is to make running changes, not model changes, whenever an improvement is possible. This affords our customers the latest in technology and engineering.

NEWPORT is a registered trademark of NEWPORT Electronics, Inc.

© Copyright 1998 NEWPORT Electronics, Inc. All rights reserved. This document may not be copied, photocopied, reproduced, translated, or reduced to any electronic medium or machine-readable form, in whole or in part, without prior written consent of NEWPORT Electronics, Inc.